



**REGO-FIX for Aerospace
and Defense Manufacturing**
Advanced toolholding guarantees precision

REGO-FIX 

REGO-FIX Soars in Aerospace Manufacturing

Extraordinary reliability and outstanding quality when precision matters

On top of the common challenges of maximizing tool life, reducing scrap and controlling costs, aerospace manufacturers in the commercial, defense and space sectors each face their own unique part production issues.



COMMERCIAL

- // Machining fuel efficient extended composite wing skins
- // Using our standard tool holding solutions for specialized processes
- // Minimizing chatter for precision, tool life and surface features



DEFENSE

- // Preventing tool pullout under heavy material removal
- // Machining material stackups for assembly operations
- // Eliminating runout for high-tolerance surface finish quality



SPACE

- // Working with new and challenging materials
- // Processing parts with complex geometries and tight tolerances
- // Machining in long-overhang tool applications

When precision matters, only the most advanced toolholding solutions will do.



Process Security When You Need It Most

REGO-FIX outperforms all others

Every REGO-FIX product is designed, manufactured and tested at our ISO-certified Tenniken, Switzerland facility to deliver extraordinary Swiss-made tooling innovations and solutions for our customers.

Developed for high-speed and high-performance cutting in aerospace, defense and space manufacturing, REGO-FIX sets the standards for rigidity and clamping force to reduce vibration with minimal total indicated runout (TIR) – even in challenging long-overhang applications.

REGO-FIX's reliability will help you optimize all your aerospace processes with consistency, repeatability and extended tool life for increased productivity and lower costs per part.



High-accuracy tooling for aerospace manufacturing

From high-speed machining to heavy roughing in tough materials and precision profiling and polishing of composites, REGO-FIX meets the challenges of aerospace, defense and space manufacturing with world-class toolholding systems and solutions.



ER Collets

REGO-FIX collets set the standard by which all other collets are measured for superior machining performance. With full lot traceability for maximum process control, REGO-FIX ER collets are 100% precision balanced for high rpm ratings and provide total indicated runout (TIR) of 10 µm Standard Precision and 5 µm Ultra Precision.



powRgrip

The REGO-FIX powRgrip toolholding system is a unique toolholder-to-collet/collet-to-tool shank press-fit system for extraordinary performance and holding capabilities. With a total system runout $\leq 3 \mu\text{m}$ at 3 X D, the powRgrip toolholding system provides tighter toolholding for finer surface finishes while providing easier setups even in difficult applications such as composites, various material stackups and splicing. Tool changeouts take only 10 seconds for reduced cycle & setup times.

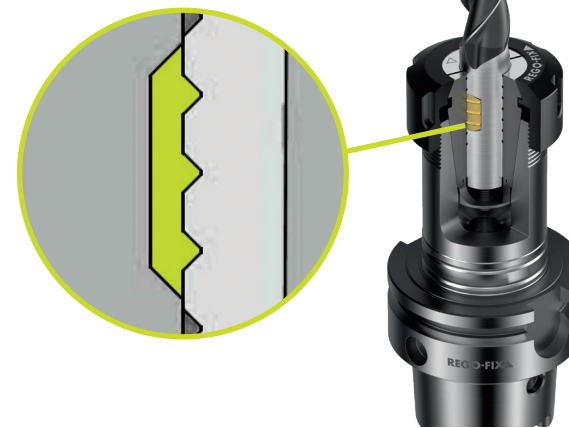

secuRgrip for powRgrip

secuRgrip is an innovative solution that provides total tool pullout protection for the powRgrip system to ensure maximum security during heavy machining. The REGO-FIX secuRgrip solution is appropriate for all tools with a Weldon flat.



CoolBore Collets

The REGO-FIX CoolBore collet provides high-pressure coolant output through the collet at the periphery of the tool shank while providing the highest clamping force of our collet coolant options. CoolBore puts coolant directly in the cutting zone for optimal chip removal and cooling with enhanced performance and vibration damping.

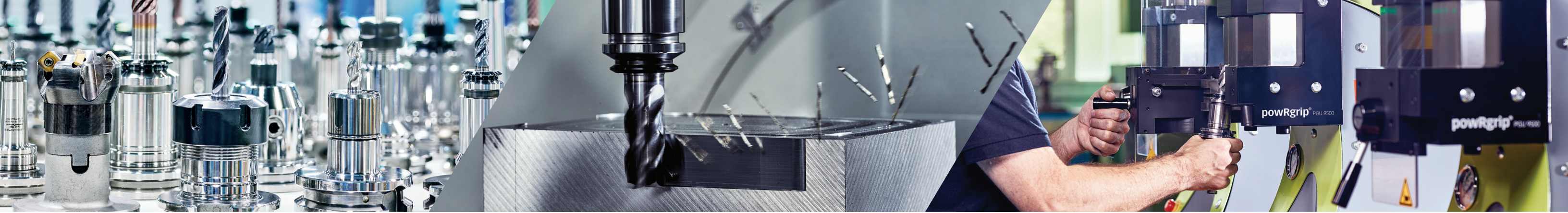

Security for every aerospace application

With a broad portfolio of the most advanced, Swiss-made toolholding available, REGO-FIX has a solution to tackle the most common challenges aerospace manufacturers face.

powRgrip for improved cycle times and unmatched precision

Our powRgrip toolholding system provides fast, safe and easy toolholding available in a variety of configurations, including CCAT, HSK, TC, BT and CAPTO for virtually any application – drill, ream, tap and mill for both roughing and finishing.

- // Tool changes in under 10 seconds with no heat, no fumes
- // 1,100 Nm of clamping torque
- // TIR of $\leq 3 \mu\text{m}$ at 3 X D and length adjustment repeatability of 10 μm
- // Excellent vibration damping for extended tool life and precision surface finishes
- // Xtended length powRgrip toolholders for applications that require longer reach or present clearance challenges, especially in horizontal milling machines
 - o MICRO-FRICTION DAMPENING® (MFD) technology dissipates vibration faster than standard long-reach holders
- // 5-year/20,000-cycle warranty
- // Common commercial aerospace sizes PG 15 & PG 25

- ▶ **Solutions for:**
Commercial
Defense
Space



REGO-FIX ER Collets: 50 years of standard-setting Swiss-made quality

Only the best will do when everything is critical. In aerospace manufacturing, REGO-FIX ER Collets are the industry standard for precision and reliability.

- // Sizes ranging from 0.008" - 1.417" (0.2 mm - 36 mm)
- // 3-point measurement of all AT3 steep tapers, exceeding the common 2-point system
- // All toolholders 100% precision balanced for use at the highest rpm ratings
- // Full lot traceability of all toolholders for maximum reliability and process control
- // Maximum ROI for improved cutting tool life

- ▶ **Solutions for:**
Commercial
Defense
Space

Enhance surface finishes and prolong tool life with CoolBore Collets

High-speed, high-torque machining is often required to process the exotic materials and super alloys of the aerospace sector. Boost your flood coolant system during high-performance and deep part feature machining with CoolBore Collets for the REGO-FIX powRgrip toolholding system.

- // Through-collet high-output coolant pressure at the periphery of the tool shank
- // Highest clamping force of all REGO-FIX coolant options
- // Coolant directly to the cutting zone eliminates chip "birdnesting," poor surface finishes and excessive tool wear
- // PG sizes 25 - 32
- // Shank diameter range 6 - 20 mm
- // Total system runout less than 3 microns
- // Reduces setup time for aiming and readjusting external nozzles
- // Eliminates non-cutting cycles for chip evacuation and tool cooling

- ▶ **Solutions for:**
Commercial

Toolholding security for big cutters

The PG48 toolholder optimizes processes for large-diameter tools and aggressive machining applications.

- // Accommodates cutters up to 40 mm (1.500") in diameter
- // TIR under 3 microns for tool lengths up to 3 x diameter
- // Length pre-adjustment with repeat accuracy of less than 10 microns
- // Incorporates a secuRgrip cap nut that effectively eliminates cutter pullout
- // Uses PGS 48 press-fit assembly unit that generates 15 tons of force

- ▶ **Solutions for:**
Defense

secuRgrip for total tool pullout protection

secuRgrip provides 100% high-performance cutting pullout protection for tools and collets to optimize productivity and secure your parts and processes.

- // PG sizes 15 – 32
- // Maximum security during heavy machining
- // Fits all standard tools with endmill flat according to DIN 6535-HB (metric)
- // No special tool shank form required
- // Common defense aerospace size: PG 32-SG

- ▶ **Solutions for:**
Defense



REGO-FIX USA
Whitestown / IN 46075 / USA

Toll Free: 800.999.7346
Phone: 317.870.5959
Fax: 317.870.5955

info.usa@rego-fix.com
www.RegoUSA.com

02/2025
COL XXXX